

burley
a warming experience



SUREFIRE

Fuel Effect Options:
Coal Effect

Control Options:

Slide Control with Convection Fan

Model No: FCC 16 Inset Coal Effect

For use on Natural Gas only (G20) at a supply pressure of 20mbar GB and IE

**Users, Installation &
Servicing Instructions**

MUST BE LEFT WITH THE USER

Manufacturer Contact Details:

Burley Magiglo
Lands' End Way
Oakham; Rutland
LE15 6RB

Tel: +44 (0)1572 725570

Fax: +44 (0)1572 724390

General E-Mail: info@magiglo.co.uk

Web Site: www.magiglo.co.uk

Technical Support: Direct Dial on **01572 725570** or email: **technical@magiglo.co.uk**

Magiglo Document Number:

CP/RC/CS

Revision Date:

June 2014

Copyright:

This documentation is copyrighted by Burley Magiglo ©2014.

No part of this document may be copied, photocopied or reproduced in any form or by any means without permission in writing from Burley Magiglo.

Magiglo is a registered trademark of Burley Appliances Ltd

Service Warranty:

In the unlikely event of a defect in materials or workmanship occurring within one year of purchase, Burley Magiglo will arrange to repair or replace the item free of charge.

Any claims under this warranty must be made through the retailer from whom the product was purchased.

As the purchaser's contract of sale is with the retailer, Burley Magiglo are unable to enter into discussions with the purchaser until the retailer has inspected any claim and deemed it to be valid.

Burley Magiglo reserve the right to refuse service or make a charge for any service call, when a defect is due to installation error or misuse.

Appliance Details:

For future reference, please complete the following information at the time of installation.

Model and **Serial Number** details may be found on the data plate as shown.

Serial Number	
Model	
Installation Date	
Installed By	

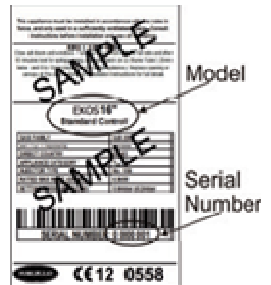

CE 12 0558

Contents

1. INNOVATION NOT IMITATION	2
2. GENERAL INFORMATION	4
2.1. Important Note About ODS Pilot.....	5
2.2. Fire Fret Dimensions.....	6
3. USER INSTRUCTIONS	7
3.1. Lighting Procedure.....	7
3.2. Electric Fan.....	7
3.3. Replacing the spark generator battery.....	7
3.4. Hot Surfaces.....	8
3.5. Fuel Effect Layout.....	8
3.5.1. Coal Effect Layout.....	9
3.6. Glass Panel.....	9
3.7. Fitting the Trim.....	10
3.8. Home Improvements.....	10
3.9. Cleaning and Care Instructions.....	11
3.9.1. Painted Metal Surfaces.....	12
3.9.2. Care of Ceramic Backs.....	12
4. INSTALLATION INSTRUCTIONS	13
4.1. General Safety Requirements.....	13
4.2. Flue Requirements.....	14
4.3. General Dimensions.....	15
4.4. Technical Data.....	16
4.5. Mantels & Combustible Shelves.....	16
4.6. Appliance Location.....	16
4.6.1. Floor Level and Raised Fireplace Openings.....	17
4.7. Ventilation.....	18
4.8. Contents Checklist.....	18
4.9. Installation Procedure.....	19
4.9.1. Preparing for the Installation.....	19
4.9.2. Installation of the Firebox.....	19
4.9.3. Connecting the Gas Supply.....	21
4.9.4. The Electricity Supply.....	21
4.9.5. Coal Effect Layout.....	21
4.9.6. Fitting the glass panel.....	22
4.9.7. Commissioning.....	23
4.9.8. Adjusting the Flue Exit Restrictor and Checking for Spillage.....	24
4.9.9. Instructing the User.....	24
5. SERVICING INSTRUCTIONS	25
5.1. General Requirements.....	25
5.2. Servicing Instructions.....	25
5.3. Replacing Parts.....	26
5.4. Pilot Assembly Replacement.....	26
5.5. Installation & Operational Troubleshooting.....	27
5.6. Parts List.....	28
5.7. Customer & Installation Notes.....	29

1. INNOVATION NOT IMITATION

Making the most of your Surefire gas fire.

Thank you very much for buying the Surefire gas fire, you now own the most efficient flued gas fire in the world. To ensure you get the most from your fire and to understand its operation, please read the information below. It has taken Burley Magiglo nearly four years to develop the numerous unique features used in this fire, the technology is so advanced that this fire is the subject of five pending patents, so it is not the same as fires you may have previously owned.

Why the Surefire is so Efficient, 94.7%.

Making the most of the gas, burning the gas completely, extracting the maximum amount of heat before the hot gases leave the fire, and minimising the heat loss from your house.

Making the Most of the Gas

The Surefire only uses a tiny amount of gas, just 2.5kWh or around 10 pence per hour. This is the same amount of gas as the smallest ring on a gas cooker, yet it will warm your house more than a 7kW conventional gas fire. The gas is burnt through a specifically designed burner and coal bed which has been designed to glow as much as possible. This red glow is heat being taken from the burning gas and being converted to radiant heat.

Glass

Radiant heat is the warmth you feel when you sit in front of the fire, the large glass screen and the angled combustion chamber ensures this is used to its fullest advantage. Each time the fire is started from cold the glass will mist over with condensation, this is normal, water vapour is a by-product of combustion and the Surefire extracts so much heat this vapour condenses. As the fire warms up the condensation will evaporate. Do not be surprised if you see small amounts of steam exiting at the bottom edges of the glass.

Burning the Gas Completely.

After passing through the coals the combustion of the gas continues in the form of the small yellowish flames, these burn quite close to the fuel bed to prevent soot forming (which is lost energy) and to allow the maximum time to heat the air inside the combustion chamber.

Catalytic Converter.

Finally, when exiting the combustion chamber, the gases pass through a catalytic converter. The catalytic converter completes the combustion process by changing carbon monoxide to carbon dioxide, releasing even more heat.

Extracting the Maximum Amount of Heat

The sides and top of the combustion chamber are made from an aluminium alloy. Aluminium allows heat to pass through it twice as quickly as steel, so far more heat is extracted from the hot gases inside.

The Inside of the combustion chamber has been designed to retain the hot gases for longer so they have more time to give up their heat. They then pass into a duct which exits to the flue. The combustion chamber and the duct have been designed to allow the air from your room to flow between them, heating the air before it is returned to your room.

Fan

A fan is located in the back of the fire. This is connected to a thermal switch which turns the fan on whenever the fire gets hot. The fan creates a coanda effect which enhances the flow of air described above by forcing it more quickly past the back and sides of the combustion chamber, extracting even more heat. The fan also causes the warm air to circulate around your room, creating a more uniform warmth and helping to remove cold spots in the room.

The fan is powered by a small adapter (provided) which plugs into a conventional wall socket. The adapter has a variable output from 3 to 12 watts so you can select your preferred speed. On the higher settings there will inevitably be a little noise from the fan, so if you are sitting reading you may wish to choose one of the lower speeds. The fire may be used without the fan connected at all, for example if there is a power cut or there is not a convenient power supply nearby, this will not damage the fire.

Minimising the Heat Loss from your House

A flued gas fire is connected to a flue or chimney to draw away the waste gases, generally this is far larger than is needed so it also draws a lot of the warm air from your room. The flue duct on the Surefire has been calculated to only allow the waste gases to be extracted with a minimal amount of heat loss.

Flue Damper

Because hot air rises, the hotter a flue or chimney gets, the harder it pulls the air. To counter this the Surefire has a unique damper which senses the temperature of the gases leaving the fire, and automatically opens or closes the opening to the flue. If you have a particularly poorly performing chimney the installer might disable this function.

Baffle to Close the Flue

Not only does the Surefire regulate the opening to the flue when the fire is in use, it also closes the flue when the fire is not in use.

A chimney or flue connected to a normal gas fire will extract all the air from an average sized room once every hour, 24 hours per day, 365 days of the year. This is a huge amount of air being lost, warm air that you have already paid to heat. Another exclusive feature of the Surefire is a baffle which closes the flue when not in use, keeping the warm air in your house. This massing saving is not included in the Surefire's 94.7% efficiency rating, it is in addition to this.

The fire is designed so it cannot be turned on when the damper is in the closed position

Slide Control

The slide control has been selected and developed to allow easy, high level, trouble free use. The operation works as follows:

- Starting at the upper position, push the slider lever down to its lower position, at this point gas is allowed through to the pilot and you will hear the ignitor clicking.
- You will see the pilot light through the coals at the front right side. Once the pilot lights, continue to keep the lever pushed down for a further 10 seconds. If it is not held down the flame failure device will not recognise that the fire has been lit and the pilot will shutdown again.
- Release the lever and lift it to roughly the half way position, this will allow gas to pass to the main burner and will light the fire on 'high'.
- Should you wish to turn the fire down, push the lever down to the lower setting.
- To turn the fire off (including the pilot light) lift the lever all the way to the top. In this position the baffle will also close the exit to the flue.

Safety

The most common problem with flues and chimneys is that if they become blocked, by a bird's nest or a collapse of masonry for example, the burnt gases from the fire can flow back into the house. The burnt gases have a high amount of carbon monoxide which can present a hazard to the occupants. With the Surefire, the burnt gases have been passed through a catalytic converter before they are allowed to leave the fire. The catalytic converter removes most of the carbon monoxide, reducing it to such a low level that even if the chimney is blocked the fire will continue to work safely.

2. GENERAL INFORMATION

Introduction

1. This appliance is suitable for installation in GB and IE and should be installed in accordance with the rules in force.

In GB, the installation must be carried out by a Gas Safe Registered Installer registered for working on this type of appliance. It must be carried out in accordance with the relevant requirements of the:

- Gas Safety (Installation and Use) Regulations.
- The appropriate Building Regulations either The Building Regulations, The Building Regulations (Scotland), Building Regulations (Northern Ireland).
- The Current I.E.E. Wiring Regulations.

Where no specific instructions are given, reference should be made to the relevant British Standard Code of Practice (see item 2).

In IE, the installation must be carried out by a Competent Person and installed in accordance with the current edition of I.S.813 "Domestic Gas Installations", the current Building Regulations and reference should be made to the current ETCI rules for electrical installation.

On completion of an installation in IE, it is necessary to complete a "Declaration of Conformity" to indicate compliance to I.S.813.

2. It is important for correct combustion of this fire that the imitation fuel is placed in accordance with the instructions given in this booklet. Only approved imitation fuel, available from Burley Magiglo., should be used with this appliance.
3. It is recommended that a fire guard complying with BS 8423 be fitted for the protection of young children, the elderly or infirm.
4. The user is warned not to throw any rubbish onto the fire or to disturb the fuel bed.
5. The user is advised that the ceramics used within this appliance require extra care whilst cleaning. Please refer to the Cleaning Instructions.
6. It is important for this fire to be serviced regularly. An annual service is recommended.

Efficiency Declaration

The efficiency of this appliance has been measured as specified in BS 7977-1-2009 with the convection fan at maximum (12 volts) and the result was 85.3%. With the fan switched off the efficiency was measured at 83%. The gross calorific value of the fuel has been used for these efficiency calculations. The test data from which it has been calculated has been certified by BSI. The efficiency values may be used in the UK Government Standard Assessment Procedure (SAP) for energy rating of dwellings.

Ventilation Requirements

1. For this model additional ventilation is not normally required in the room that the fire is fitted. However, if spillage is detected during spillage test additional ventilation may be required. In GB reference should be made to BS 5871:Part 2, and in IE, reference should be made to the current edition of I.S.813 which makes clear the conditions that must be met to demonstrate that sufficient ventilation is available.
2. Any purpose provided ventilation must be checked periodically to ensure it is free from obstructions.
3. When fitting the fire in Northern Ireland (NI), purpose provided ventilation must be provided in accordance with the rules in force.
4. In other EC countries equivalent rules in force must be used.

Gas Supply

1. This gas fire is suitable for use with Natural Gas (12H) at 20mbar +/- 1 mb supply pressure.
2. Connection to the gas supply must be made using rigid or semi-rigid tubing.
3. A separate means of isolating the gas supply should be provided near to the appliance to facilitate servicing. An isolating valve has been supplied for this purpose.

Electrical Supply

1. If necessary install a mains socket near the appliance.
2. Plug the power supply / transformer unit into an adjacent socket and route the cable to the appliance and insert the DC plug into the socket behind the fret on the left hand side of the appliance. The cable should be installed through a conduit sufficiently large to accommodate the DC plug so that replacement of the power supply / transformer unit is possible. The fan is switched automatically as the fire warms and cools.

Note; the power supply unit is supplied with a selection of DC plugs. Choose the one that fits the socket on the fire and connect it to the socket on the lead from the PSU with side showing centre positive next to the arrow.

2.1. Important Note About ODS Pilot

This fire is fitted with an ODS pilot which causes the appliance to shut down in the event of a reduction of oxygen (e.g. caused by poor ventilation) in the room. Should this happen, follow the lighting instructions to re-light the fire. In the event that the fire should shut down again, do NOT attempt to re-light it but contact your gas installer for remedial action to be taken.



Under no circumstances should it be adjusted or put out of action by the installer or the user. If the pilot needs replacing, only the approved part (available from your supplier or Burley Magiglio.) should be fitted. Note: if any part of the pilot assembly becomes faulty the complete assembly will need replacing.

2.2. Fire Fret Dimensions

All models can be used with the Burley Magiglo range of frets or any other fire frets that falls within the dimensions shown below

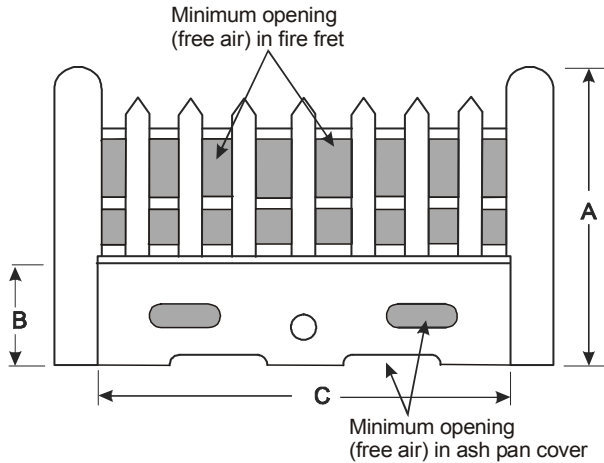

Figure 1

Fire Front Specification

Height to Centre (A)	Maximum	9 Inches (23cm)
	Minimum	6 Inches (15cm)
Ash Pan Cover Height (B)	Maximum	3.5 Inches (9cm)
	Minimum	2.5 Inches (6.4cm)
Ash Pan Cover Free Air Opening	Minimum	5 sq. Inches (32.3cm ²)
Fire Fret Free Air Opening	Minimum	15% of total fire front area above the base of the fire
Ash Pan Cover Length (C)	Maximum	13.5 Inches (34cm)
	Minimum	12.5 Inches (32cm)

3. USER INSTRUCTIONS

3.1. *Lighting Procedure*

The pilot can be viewed by looking downwards over the front ceramic between the first and second coals from the right hand side.

Press the control lever firmly down to the bottom of its travel and listen for the spark generator clicking which should light the pilot.

Hold down for a further 10 seconds.

If the pilot should fail to stay alight slide the control lever to the top of its travel, wait 3 minutes and repeat the procedure.

Once the pilot is alight lift the control lever to the desired heat setting.

To turn off the fire lift the control lever to the top of its travel.

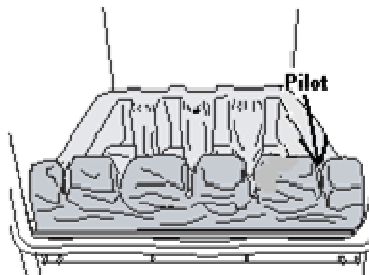

The off position on the side of the fire may not correspond exactly with the control lever. This is only intended as an indication.

3.2. *Electric Fan*

Your fire has been fitted with a low voltage electric convection fan to improve its efficiency.

The fan is controlled by a temperature sensitive switch and will start automatically as the fire warms up and will switch off as the fire cools. It may continue to run after the fire is turned off as the fire will take some time to cool down.

If you do not wish to use the fan, turn off the socket that its power supply unit is plugged into. Alternatively the fan speed can be reduced by selecting a lesser voltage by turning the selector switch on the rear of the power supply unit.

A small key is supplied to do this or a flat bladed screwdriver may be used. The efficiency of the appliance is slightly reduced by selecting a lesser fan speed or by turning the fan off.

3.3. *Replacing the spark generator battery*

Remove the ash pan cover. Locate the spark generator which is fitted near the centre of the burner with the battery facing outwards.

Ease out the battery from the right hand end of the battery holder and remove the battery. Replace with a good quality 1.5v AA size battery ensuring the polarity markings on the battery correspond with the markings on the battery holder.

Check the spark generator clicks when the control linkage is depressed downwards.

3.4. Hot Surfaces

Certain parts of this appliance get very hot during normal use. It is therefore recommended that a suitable fireguard (to BS8428:2010) be used for the protection of young children and the infirm. The shaded parts in the illustration below show the 'Working Surfaces' on the appliance.

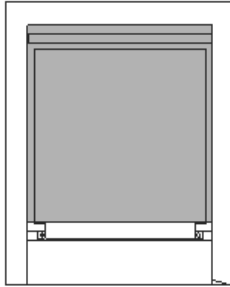

All shaded portion is working surface

3.5. Fuel Effect Layout

You fire has been supplied with a Coal effect fuel bed. Please refer to the relevant section for instructions on how to arrange the imitation fuels.

Constant moving of the imitation fuel will cause the fuel to disintegrate and/or cause discolouration.

RCF Advice:

This product may use Coals containing Refractory Ceramic Fibres (RCF), which are man-made vitreous silicate fibres. Excessive exposure to this material may cause irritation to eyes, skin and respiratory tract.



Therefore during installation and servicing we recommend that you use a HEPA filtered vacuum to remove any dust and soot accumulated in and around the fire before and after working on the fire, to ensure that the release of fibres from these RCF articles is kept to a minimum.

We recommend that you should follow the normal hygiene rules of not smoking, eating or drinking in the work area.

When replacing Components containing Refractory Ceramic Fibres (RCF), we recommend that the replaced items are not broken up, but are sealed within heavy duty polythene bags, and clearly labelled as RCF waste. RCF waste may be disposed of in suitably licensed landfill sites.



WARNING: Do not touch the fire when it is alight. The fire will remain very hot for a long while after extinguishing.

3.5.1. Coal Effect Layout

The fire is supplied with a set of ceramic fuel bed components as follows:

A three piece set of: lining boards, one left hand side, one right hand side and a rear board.

One Moulded Front Ceramic, Moulded Rear Ceramic, Moulded Coal Matrix, Coal with round peg and one Coal with square peg.

Place the ceramic components as follows:

Hold the rear board in position and then place the left and right side boards in position with the curved edges upwards and the black faces visible.

Position the rear burner ceramic in position behind the rear burner flange.

Place the front burner ceramic in its support in front of the burner. Manipulate the rear ceramic so that the front ceramic slides in easily.

Place the moulded coal matrix on top of the rear ceramic so that the front rests on the front ceramic.

Place the two pegged coals in position.

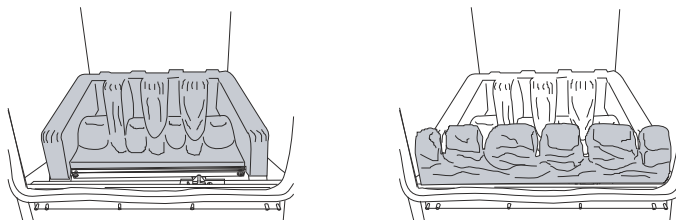

3.6. Glass Panel

The user is warned not to remove the glass panel or to disturb the fuel bed.



WARNING: If any cracks appear in the glass panel do not use the appliance until the glass panel has been replaced by a qualified installer.

3.7. *Fitting the Trim*

1. Fix the infill frame onto the front of the appliance using the four screws provided
2. Most trims are coated with a protective film. This must be removed by peeling off before fitting the trim.
3. The trim is held on by four magnets. These will either be attached to the trim or supplied loose in a separate envelope. Space them as shown in **Figure 2**.
4. Offer the trim onto the flange of the firebox. The magnets will hold the trim in position.
5. Centralise the trim as necessary.

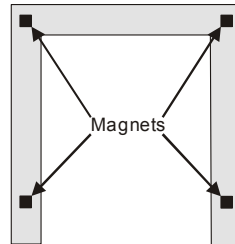

Figure 2

3.8. *Home Improvements*



WARNING: If after installation of this fire any home improvements (e.g. double glazing, secondary double glazing, draught proofing, fitting extractor fans, etc.) are carried out to the property it is essential to carry out a spillage test on the fire to ensure that the flue is still operating satisfactorily.



NOTICE: Discolouration of wall surfaces

Generally, heating appliances will create warm air convection currents that will transfer heat to any wall surface against which they are located. Some soft furnishings (including blown vinyl wallpapers) may not be suitable for use where they are likely to encounter temperatures above the normal room level. For this reason, the manufacturer's advice should be sought before using this type of wall covering adjacent to any heating appliance.

The likelihood of wall staining caused from convected air currents will be increased in areas where high levels of tobacco smoke or other contaminants exist.

3.9. **Cleaning and Care Instructions**



CAUTION: Ensure that the appliance is off (including the pilot light) and has completely cooled (off for at least 2 hours) before carrying out any cleaning or maintenance.

RCF Advice:

This product may use Components Coals, containing Refractory Ceramic Fibres (RCF), which are man-made vitreous silicate fibres. Excessive exposure to this material may cause irritation to eyes, skin and respiratory tract.

Therefore during installation and servicing we recommend that you use a HEPA filtered vacuum to remove any dust and soot accumulated in and around the fire before and after working on the fire, to ensure that the release of fibres from these RCF articles is kept to a minimum.

We recommend that you should follow the normal hygiene rules of not smoking, eating or drinking in the work area.

When replacing Components containing Refractory Ceramic Fibres (RCF), we recommend that the replaced items are not broken up, but are sealed within heavy duty polythene bags, and clearly labelled as RCF waste. RCF waste may be disposed of in suitably licensed landfill sites.



Black Painted Surfaces;

These surfaces should be dusted regularly and any marks removed with a soft damp cloth.

Brass or Chrome Surfaces;

These surfaces should be cleaned with a proprietary non-abrasive metal cleaner.

Remove the trim (if fitted), the fret and the ash-pan cover before cleaning.

The trim is held in place by means of four magnets at the rear of the trim. The fret and the ash-pan cover are free standing in front of the fire.

Stainless Steel

Stainless steels need to be cleaned for aesthetic considerations and to preserve corrosion resistance.

Oil and finger marks can be removed using a glass cleaner or preferably a mild solution of warm water and detergent.

Scratches can be removed by gently rubbing in the direction of the grain with a 240 grit emery cloth (or similar). Once the scratch has been completely removed the surface can then be re-polished using 3M Scotchbrite pads - Fine Grade.

Periodically it may be necessary to coat the entire surface in order to achieve a uniform finish. This can be achieved by applying a light coat of oil (baby oil) using a soft lint free cloth, then buffing in line with the grain until the excess is removed.

NOTE: After any cleaning process the surface must be thoroughly dried before lighting the appliance..

3.9.1. Painted Metal Surfaces

These surfaces should be dusted regularly and any marks removed with a soft damp cloth.

3.9.2. Care of Ceramic Backs

The ceramic fireback on this appliance must NOT be sprayed with any type of solvent-based high temperature paint.

The very high temperatures produced within the appliance will cause the paint to bubble and/or burn off rendering the fireback looking unsightly.

Minor surface scuffs may be treated using a water based touch up stain available at Burley Magiglo fire retailers.



Extreme care should be taken when handling and installing products containing ceramic interiors, so as not to cause damage.

4. INSTALLATION INSTRUCTIONS

Before installation, ensure that the local distribution conditions (identification of the type of gas and pressure and the adjustment of the appliance are compatible)

4.1. *General Safety Requirements*

The installation of the fire should also follow the recommendations of the following current British Standards (or equivalent):

BS 6891	Pipe work Installation
BS 5440: Pts 1 & 2	Flues and Ventilation
IGE/UP/7 IGE	Document for gas installations in Timber Frame Buildings (Available from Institute of Gas Engineers & managers)
BS5871-2 – 2005 Part 2:	Inset live fuel effect gas fires of heat input not exceeding 15kW.
BS EN 1856	Chimneys - Requirements for metal chimneys - System chimney products
BS EN 1858	Chimney – Components – Concrete flue blocks
BS 715	Metal flue boxes

It is important for correct combustion of this fire that the imitation fuel is placed in accordance with the instructions given in this and associated booklets. Only approved imitation fuel, available from Burley Magiglo, should be used with this appliance.

Combustible shelves or materials must only be fitted above the fire in accordance with the instructions given in this and associated booklets.

4.2. Flue Requirements

This appliance may be installed in fireplaces served by the following types of flue;

Class 1 Masonry Flue - A flue having no cross sectional dimension less than 175mm (7") e.g. 225mm (9") by 225mm (9") Masonry chimney or 175mm (7") diameter clay liner. Due to the high efficiency of this appliance consideration should be given to lining any unlined masonry flue with a flexible flue liner to prevent problems with condensation.

Class 2 – A metal flue having no cross sectional dimension less than 125mm (5"). All metal flues must comply with the requirements of BS EN 1856 "Chimneys - Requirements for metal chimneys - System chimney products". Any metal flue box must comply with BS 715 and be large enough to accept the appliance. There must be a minimum of 50mm clearance from any combustible material; alternatively the box may be insulated with 25mm mineral wool or equivalent. The top of the box must be insulated with 25mm mineral wool or equivalent

Class 2 - Pre-cast - A flue constructed of pre-cast concrete/terracotta blocks conforming to BS EN 1858 or BS 1289:Part 1 and having a minimum cross sectional area of 12,272mm² with the smallest dimension being no less than 63mm.

All flues require a minimum height of 3 metres (10ft). For installation in GB, please refer to BS 5871 Part 2 for further information. For installation in IE, refer to the current edition of I.S.813 "Domestic Gas Installations".

A faulty flue or chimney may result in smoke and fumes entering the room.

The flue should be sound, free from obstructions and, if it has previously been used with a solid fuel or oil fired appliance, it should be swept before installing this gas fire. The flue must be inspected annually to ensure continued clearance of combustion products. Any flue damper plates or obstructions etc. must be removed and no restrictor plates shall be fitted. Where removal is not practical, the damper plate/restrictor must be fixed permanently in the fully open position.

Note: To comply with the expression "permanently fixed in the open position", a mechanical fixing that prevents user intervention should be used e.g. requires the use of tools for removal.

It is recommended that a smoke test be carried out before installation to ensure that there is no spillage of fumes into the room. If spillage occurs this problem must be rectified before commencing installation.

The flue must serve only one appliance.

If any terminal, cowl or chimney pot is fitted on the flue, ensure that it is suitable for use with this gas fire and the flue system and does not restrict the cross sectional area of the flue. Please consult the manufacturer of the terminal/cowl/chimney pot for guidance.

On completion, the installation must be thoroughly tested for spillage as detailed in the Commissioning section of the Installation instructions.

4.3. General Dimensions

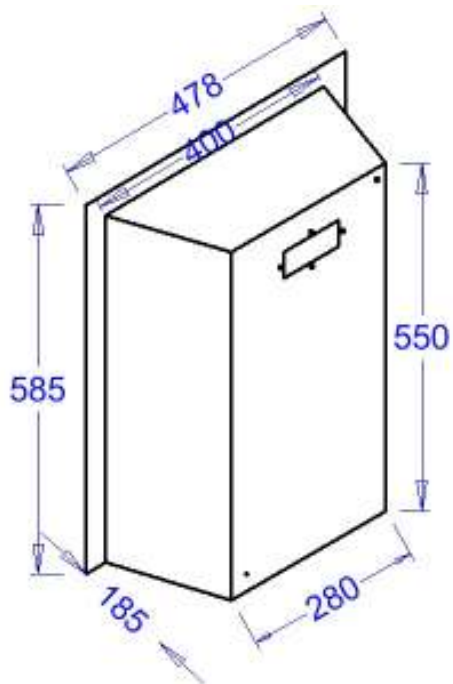

4.4. Technical Data

	Natural Gas
Nominal maximum heat input	2.5kW (gross)
Minimum heat Input	1.5 kW (gross)
Inlet Pressure	20 mbar ±1mbar
Gas	I2H (Natural Gas)
Injector Type	No.180
Gas inlet connection	8mm
Control valve	Teddington TESA 3173/0014/A
Pilot	Seagus P441

4.5. Mantels & Combustible Shelves

Shelves or mantels made from combustible materials should not be placed closer than 300mm above the appliance.

Light coloured and resin mantels may discolour in time. The temperature rating of the surround should be checked before use.

We recommend a fire surround with a minimum 150 degrees Celsius rating.

4.6. Appliance Location

In all installations we recommend a non-combustible back panel is used. We do not recommend installing the appliance against a plastered wall without a back panel.

The appliance may be sited at floor level (with a 50mm high hearth or fender) or as a raised hearth installation.

The fire must be fitted on a flat non-combustible base. In addition a non-combustible hearth with minimum dimensions shown in figures below should be provided in front of the fireplace opening.

4.6.1. Floor Level and Raised Fireplace Openings

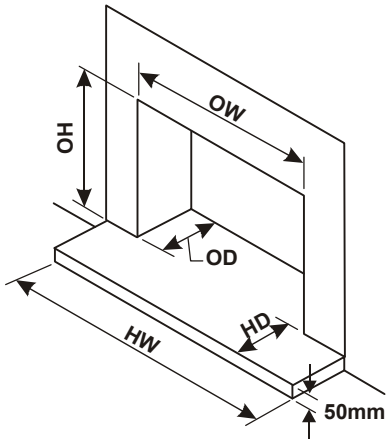

Figure 3

Floor Level Openings	
OH	560mm
OW	405mm
OD	235mm (min)
	Raised Installation HD + HF Height of Hearth from Floor = at least 225mm

Table 1

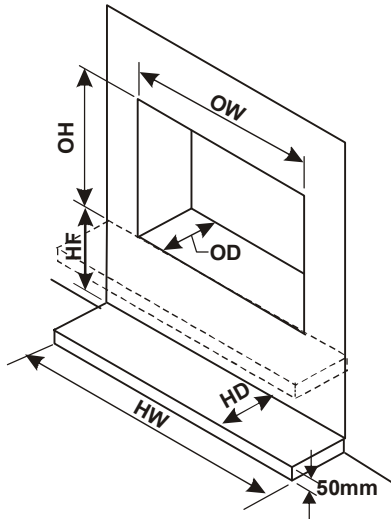

Figure 4



Hearth Construction: The hearth material must be non-combustible and a minimum of 12mm thick, when laid on the floor. Either a 50mm upstand above the finished floor level must be created or a fixed fender must be used.

4.7. Ventilation

1. For this model additional ventilation is not normally required in the room that the fire is fitted. However, if spillage is detected during spillage test additional ventilation may be required. In GB reference should be made to BS 5871:Part 2, and in IE, reference should be made to the current edition of I.S.813 which makes clear the conditions that must be met to demonstrate that sufficient ventilation is available.
2. Any purpose provided ventilation must be checked periodically to ensure it is free from obstructions.
3. When fitting the fire in Northern Ireland (NI), purpose provided ventilation must be provided in accordance with the rules in force.
4. In other EC countries equivalent rules in force must be used.

4.8. Contents Checklist

Before proceeding with installation of the fire check the contents as follows:

Quantity	Item
1	Gas Fire
1	Ceramic Component Set <i>Base / Front / Matrix / 2x Loose coals-</i>
1	Isolating Valve
1	Sealing Strip
1	Cable Fixing Kit
1	Manufacturer's Instructions
1	Power Adapter

4.9. Installation Procedure



Before commencing installation, ensure that the intended installation will comply with details in **General Information** on Pages 2 and 5.

The Burley Magiglo FCC 16 is designed to be inset into a 16" fireplace opening. Any surround that is to be installed with this appliance must be rated at 150oC.

The installation of this appliance must be carried out by a competent person in accordance with the current Gas Safety (Installation and Use) Regulations (as amended). It is mandatory that all gas installers are Gas Safe registered.

4.9.1. Preparing for the Installation

Carefully unpack the contents of the carton and check them against the checklist given on the previous page.

Make sure that the fireplace opening is suitable for the installation of the fire and prepare the fireplace to suit the dimensional requirements given in section 4.6 (i.e. fitting the fire surround, the hearth (if required) etc.).

Apply the sealing strip around the rear edge of the flange.

Remove the louvre panel secured by three screws and then the four screws holding the upper glass clamp, remove the glass panel. Store the louvre and glass panels in a safe place during the installation process.

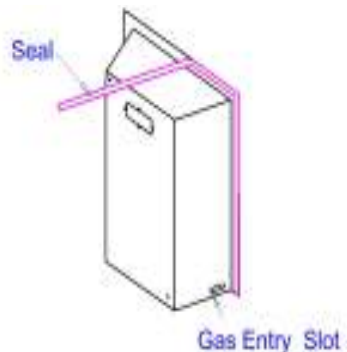

4.9.2. Installation of the Firebox

1. Mark out, drill, plug and fit the two eye screws onto the rear wall of the fireplace opening as shown below. Thread the cable through the lower hole in the (right hand) side of the firebox and then out of back hole. Place the appliance close to the fireplace opening and feed the cable through the two eye screws and then back into the upper hole in the back of the firebox. Whilst pulling the cable push the firebox gently into the opening until its flange meets the fire surround.
2. Slide the short piece of 8mm tube way onto the cable followed by the tensioning screw.
3. Whilst holding the cable tensioning screw pull the cable taut and without releasing the tension tighten the thumb screw firmly. To further tighten the cable screw the wing nut clockwise.
4. Roll up the excess cable and tuck it away. DO NOT CUT OFF the excess cable. Ensure the excess cable does not foul the flap mechanism.
5. Remove the grommet from the gas inlet slot on the firebox to allow for gas pipe to come through. (Ensuring that the gas pipe emerges from the slot at the left hand side of the appliance).

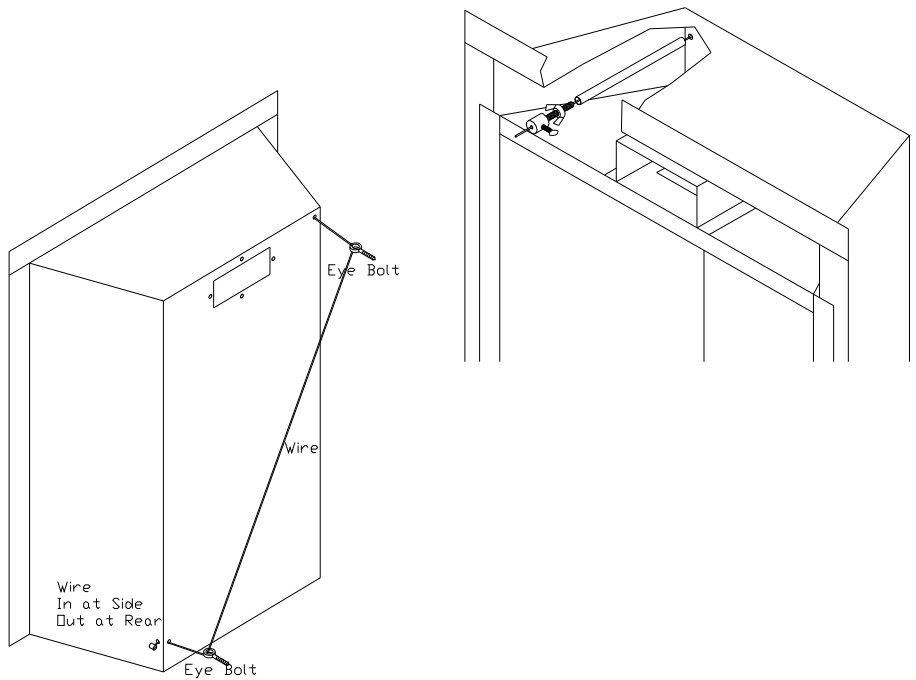
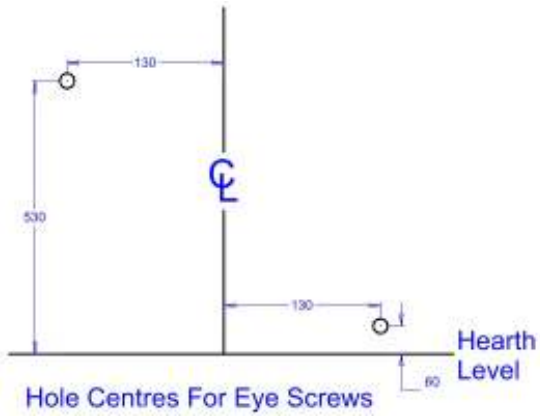

4.9.3. Connecting the Gas Supply

The gas supply to the fire must be carried out using rigid or semi-rigid metal tubing. A service cock must be incorporated near the appliance to facilitate isolation of the fire during servicing. An isolating valve (with a pressure test point) has been supplied with this fire.

The gas supply must be fed into the firebox through the aperture on the left hand side. Care should be taken to sleeve the pipe when passing through masonry.

Make an appropriate slit in the rubber grommet and feed the gas supply pipe through it. Seal the gas inlet slot with the grommet.

Connect the outlet of the isolating valve to the supply pipe leading to the control valve. The outlet on the isolating valve is the one next to the pressure test point.

4.9.4. The Electricity Supply

If necessary install a mains socket near the appliance.

Plug the power supply / transformer unit into an adjacent socket and route the cable to the appliance and insert the DC plug into the socket behind the fret on the left hand side of the appliance. The cable should be installed through a conduit sufficiently large to accommodate the DC plug so that replacement of the power supply / transformer unit is possible. The fan is switched automatically as the fire warms and cools.



Note; The power supply unit is supplied with a selection of DC plugs. Choose the one that fits the socket on the fire and connect it to the socket on the lead from the PSU with side showing centre positive next to the arrow

4.9.5. Coal Effect Layout

The fire is supplied with a set of ceramic fuel bed components as follows:

A three piece set of: lining boards, one left hand side, one right hand side and a rear board.

One Moulded Front Ceramic, Moulded Base Ceramic, Moulded Coal Matrix, Coal with round peg and one Coal with square peg.

Place the ceramic components as follows:

Hold the rear board in position and then place the left and right side boards in position with the curved edges upwards and the black faces visible.

Position the Base burner ceramic in position behind the rear burner flange.

Place the front burner ceramic in its support in front of the burner. Ensure that the front ceramic slides in easily and is upright.

Place the moulded coal matrix on top of the base ceramic so that the front rests on the front ceramic. Push it back so that it touches the rear lining board.

Place the two pegged coals in position.

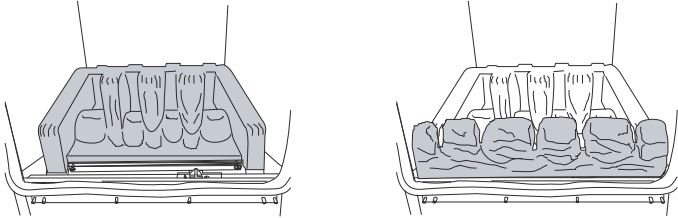

4.9.6. Fitting the glass panel

Refit the glass panel by seating it centrally behind the lower clamp and securing by fixing the upper clamp in position with the four screws previously removed.

Please ensure that all finger prints and oil marks are removed from the glass before re-fitting. Wear gloves to prevent marking.

4.9.7. Commissioning

1. Turn on the gas supply to the fire and purge the gas line. Check all the gas joints for gas soundness.
2. Remove the pressure test point screw and connect a pressure gauge.
3. Ignite the pilot in accordance with the User Instructions.
4. Set the controls to give full gas rate at the main burner.
5. Ensure that the pressure at the pressure test point is between 19 and 21 mbs. Alternatively the information is given on the data badge of the appliance.
6. If the correct pressure cannot be achieved, then some potential causes of low pressure are:
 - a) Supply pipes are not of large enough diameter.
 - b) The supply pipes are blocked or partially blocked.
 - c) Restriction at the appliance isolation valve.
6. Turn the fire off and replace the pressure test point screw.
7. Fit the appropriate fire-front
8. Proceed to carry out a spillage test.

4.9.8. Adjusting the Flue Exit Restrictor and Checking for Spillage



The imitation fuels must be laid in accordance with the instructions prior to commencing the spillage test.

from the upper hole to the lower hole in its bracket. Before screwing the limit screw home push the thermostat arm down so that it is under the limit screw's new position. Check that the restrictor flap is in its lowest position.

6. If it is not possible to adjust the appliance so that there is no spillage this may indicate either an installation fault or a flue construction fault. Disconnect the fire and seek expert advice.
7. If the spillage test is satisfactory replace the louvre and secure with the three screws.

1. Close all doors and windows.
2. Turn the fire on to its full rate and leave it burning for 5 minutes.
3. Test for spillage using a smoke match (in a 'Blume tube') at the top of the appliance, fireplace opening or under the canopy at the centre, with the smoke match being approximately 25mm under and 12-15mm inside the opening (see **Figure 5**).
4. If the test indicates spillage, repeat the test after a further 10 minutes.

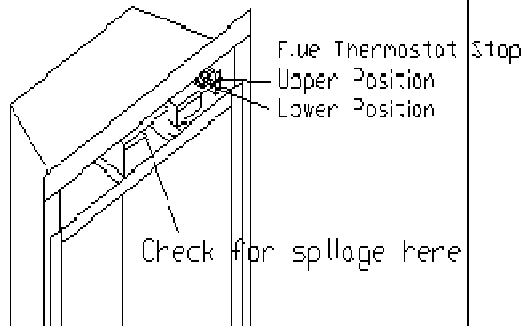

Figure 5



If there are any extractor fans in the nearby rooms then repeat the smoke match test with all these fans operating and any interconnecting doors open between the fans and the fire

5. If spillage is detected set the restrictor flap in the fully open position by moving the thermostat operating arm limit screw

4.9.9. Instructing the User

The installer must hand over these instructions to the user and explain how to operate this fire, stressing the importance of having the fire checked and serviced regularly. An annual service is recommended.



It is mandatory as part of the gas installation that the installer instructs the user on the correct operation and care of their appliance.

5. SERVICING INSTRUCTIONS

5.1. General Requirements

All repairs and servicing must be carried out by a qualified registered gas installer (e.g. member of Gas Safe in GB) in accordance with the current Gas Safety (Installation and Use) Regulations and these instructions.

Before any servicing is carried out ensure that the gas and electrical supply / transformer is unplugged.

Always check for gas soundness after dismantling or exchange procedures.

On completion of the servicing, a spillage test must be carried out.

5.2. Servicing Instructions

1. Remove the glass panel as described in the installation section and place it in a safe place.
2. Carefully remove the two loose pegged coals from the top of the fuel bed. Carefully remove the fuel bed moulding. Lift out the front and rear ceramics. Also remove the three ceramic fibre lining boards. Any debris/dust or soot can be brushed off using a soft brush.
3. Turn off the gas supply at the isolator fitting. Disconnect the gas supply. Remove one of the nuts in the slider control linkage and disconnect the linkage from the burner chassis at actuating lever on front of gas burner. Remove the two screws at the rear and the two screws at the front securing the burner chassis and gently lift it out of the appliance. Clean the burner slot with a brush.
4. Check that the electrode sparks across the gap when the slider lever is pushed to the left.
5. Use a vacuum cleaner to remove any fluff or lint on the base of the combustion chamber.
6. Undo the two securing screws holding the fan shroud to the rear of the firebox and lift clear. Clean the circulation fan with the vacuum cleaner and check the foam strip around the end flanges is in good condition. Replace if necessary.
7. Replace the fan in position ensuring that the motor does not touch the side of the appliance.
8. Replace the fan shroud and secure with the two screws previously removed.
9. Loosen the cable fixing clamp and slide the appliance forward.
10. Inspect and clean the flue as necessary.
11. Replace the appliance and tighten the fixing cable.
12. Refit the burner chassis and secure in place using the previously removed screws. Reconnect the gas supply, turn on at the isolator fitting and check for leaks. Reconnect the slider control linkage.
13. Replace the lining boards.
14. Replace the front and rear ceramics and replace the moulded fuel bed and loose coals as described in the appropriate fuel bed layout sections 3.9.5
15. Refit the glass panel and secure in place using the clamp and self tapping screws previously removed. Note; No.6 self tapping screws have been used from new, if a screw strips its thread replace with a No.8 sized screw.
16. Light the appliance and after letting it warm carry out spillage test as detailed in the installation section
17. Replace louvre, trim and fret.

5.3. Replacing Parts

For any spare parts that are required, please contact either your supplier or the manufacturer directly. You will either need the **serial number** or: a) model name; b) the gas type; c) the imitation fuel type; d) the type of control.

Only approved parts should be used.

5.4. Pilot Assembly Replacement



NOTE: If any part of the pilot assembly becomes faulty then the whole pilot assembly will need changing.

1. Remove and replace the burner chassis as detailed previous section.
2. Remove the HT lead from the end of the electrode.
3. Cut the cable tie wrap.
4. Using M9 spanner undo the thermocouple connection from behind the control valve
5. Using M10 spanner undo the pilot feed

RCF Advice:

This product may use Components (Coals, Ceramic backs) containing Refractory Ceramic Fibres (RCF), which are man-made vitreous silicate fibres. Excessive exposure to this material may cause irritation to eyes, skin and respiratory tract.

Therefore during installation and servicing we recommend that you use a HEPA filtered vacuum to remove any dust and soot accumulated in and around the fire before and after working on the fire, to ensure that the release of fibres from these RCF articles is kept to a minimum.

We recommend that you should follow the normal hygiene rules of not smoking, eating or drinking in the work area.

When replacing Components containing Refractory Ceramic Fibres (RCF), we recommend that the replaced items are not broken up, but are sealed within heavy duty polythene bags, and clearly labelled as RCF waste. RCF waste may be disposed of in suitably licensed landfill sites.



5.5. Installation & Operational Troubleshooting

The table below is intended for problems related to the fire and its gas controls. It is a guide only and does not take into account every eventuality. Servicing must be carried out in accordance with the current Gas Safety (Installation and Use) Regulations, by a competent person.

It is recommended that the purchaser seek the advice of the original installer in case of encountering any problems.

Symptom	Cause	Remedy
No spark appears at the electrode	a) Electrode cracked or broken	Replace pilot assembly
	b) HT lead shorting out on burner body	Establish where spark is occurring and insulate or re-route lead accordingly.
	c) Faulty spark generator	Replace valve
Spark Generator operates normally but pilot will not light	a) No gas supply	Check isolation valve/supply
	d) Spark Generator Battery Flat	Replace Battery
	b) Pilot jet blocked	Replace pilot assembly
Pilot lights, but goes out when control is released	a) Loose thermocouple connection at control valve end	Remake thermocouple ensuring the connection is firm
	b) Faulty Thermocouple	Replace complete pilot assembly
Pilot and main burner go out when control is set to high position	a) Gas supply partially blocked	Locate restrict and remove faulty section
	b) Too many bends on gas inlet pipe	Increase diameter and/or reduce the number of bends
	c) Pilot jet partially blocked	Replace complete pilot assembly
	d) Restriction at Isolation valve	Ensure valve is fully open and that internal diameter is sufficient and free from grease
Fumes enter room when the fire is in operation	a) Blocked flue	Remove blockage in flue
	b) Insufficient replacement air	Check air vents are free of obstructions



Warning: If you are in any doubt about the clearance of fumes, you must stop using the appliance immediately and seek expert advice. Do not use appliance until the fault has been rectified.

Installation & Operational Troubleshooting – cont.



NOTE: If any part of the pilot assembly (i.e. thermocouple, electrode, jet or burner) becomes faulty the whole pilot assembly will need changing.



NOTE: For any spare parts that are required, please contact your. You will either need the **serial number** or: a) model name i.e. Surefire™; b) the gas type; c) the imitation fuel type; d) the type of control.

Only approved parts should be used.

5.5.1.Parts List

DESCRIPTION	Surefire	
	PART NO	QTY
GLASS		1
OXY PILOT		1
CERAMIC SET		1
SEALING STRIP		1
CABLE FIXING		1

5.6. Customer & Installation Notes

Date of Installation:

Gas Safe Installer Name & contact details

Serviced

Date

Notes:



Magiglo fires are protected by
UK patents 2193802, 2240620 and 2256920
Other Patents Pending

Magiglo is a registered trademark of Burley Appliances Ltd.



Burley Magiglo, Lands End Way,
Oakham; Rutland, LE15 6RB

Tel: 01572 725570 Fax: 01572 724390
www.magiglo.co.uk Email: info@magiglo.co.uk